

LDI-RFDA 4-20mA LEVEL SENSOR ADAPTER FOR LDI ROW



LDI-RFDA 4-20mA LEVEL SENSOR ADAPTER FOR LDI ROW

This document describes the basic functionality, setup, wiring and configuration procedures of LDI-RFDA 4-20mA Level Sensor Adapter for ROW.

NB! This document assumes user to have familiarity with ROW, its general settings, wiring specifications, limitations and precautions.

Table of Contents

- Introduction..... 3
- Mechanical 3
- Electrical 5
 - Electrical Characteristics 5
 - Ports 5
- Connectivity and wiring..... 6
 - Power supply considerations 6
 - Connecting ROW 6
 - Connecting the level sensor 8
 - Monitoring equipment..... 9
 - ATEX considerations..... 10
- Configuration and setup..... 11
 - 4-20mA Current Loop Configuration..... 11
 - Serial Port Settings 12
 - ROW Parameters and Polling 12
- Advanced functionality..... 13
 - PLC and Data Logger considerations 13
 - Reading the water distance by external devices 13
 - Automatic updates..... **Error! Bookmark not defined.**
 - Modbus reference and register map 13
- Appendix 1. Modbus Register Map..... 14

LDI-RFDA 4-20mA LEVEL SENSOR ADAPTER FOR LDI ROW

Introduction

Initially, ROW is designed to work directly with Senix ToughSonic series Modbus-supporting level sensors. To this end, ROW is capable of interacting with these sensors over RS-485. However, another kind of level sensor might be required by the end user.

Many distance sensors include 4-20 mA current loop to provide distance values. For this reason, the LDI-RFDA adapter has been developed to interface ROW with these sensors.

LDI-RFDA adapter converts 4-20mA output of a level sensor to the digital value and provides it over RS-485 in a Modbus packet that ROW is capable of interpreting.

Mechanical

LDI-RFDA comes in a compact box with the dimensions of 66x66x24mm. The adapter is intended to be installed in an equipment closet or a junction box where ROW and rangefinder cables terminate.

NB! The enclosure of LDI-RFDA adapter itself is not waterproof nor protected from environmental effects.

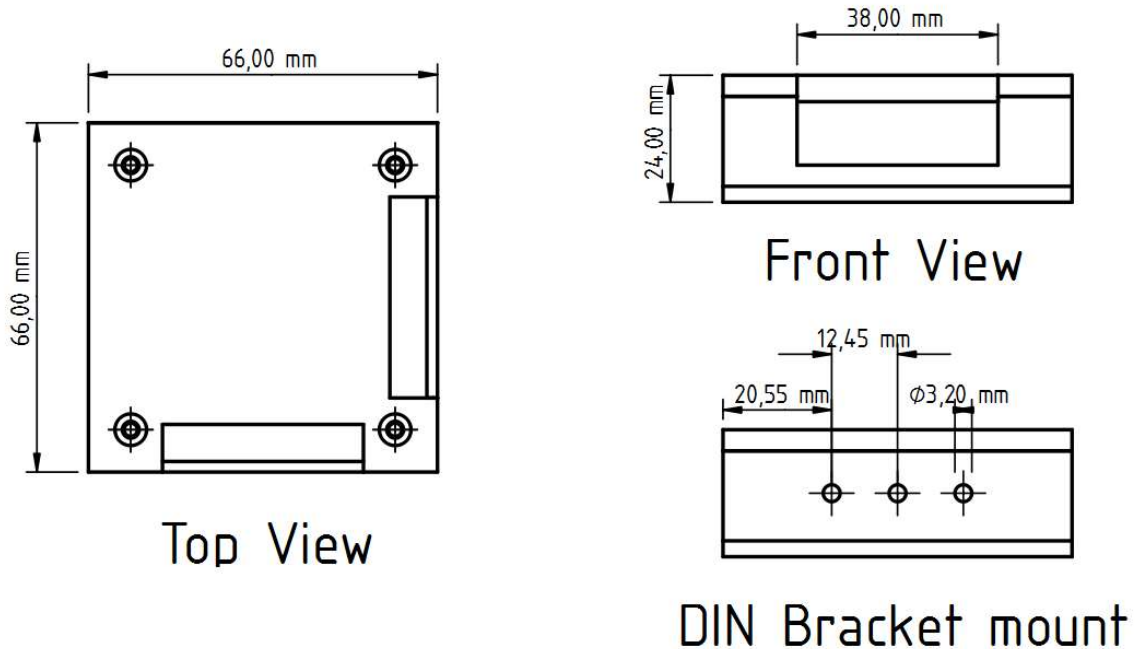

Figure 1. LDI-RFDA mechanical drawing and dimensions

Enclosure material: PLA plastic.

For easier mounting of LDI-RFDA adapter in junction boxes, a DIN-rail bracket may be attached to the enclosure. The enclosure has mounting holes intended to attach a *Moxa*

LDI-RFDA 4-20mA LEVEL SENSOR ADAPTER FOR LDI ROW

DK35A DIN-rail mounting kit, which can be installed upon request at LDI. Information about the kit, including the dimensions and drawings, may be found on the manufacturer’s web site:

<https://www.moxa.com/en/products/accessories/mounting-kits/din-rail-mounting-kits/din-rail-mounting-kits/dk35a>



Figure 2. LDI-RFDA adapter with DK35A DIN-rail mounting clip

Electrical

LDI-RFDA adapter should be installed at the end point of ROW and the level sensor cables, acting as a distribution board. Therefore ROW, level sensor, power supply and optionally an RS-485 output for monitoring hardware (PC, PLC, etc) should all be wired into the adapter.

Electrical Characteristics

Table 1. Electrical Characteristics of LDI-RFDA adapter

Parameter	Value
Supply Voltage	12..30 VDC
Power Consumption	< 0.1 W
Current Loop Load Resistance	210 Ohm
Current Loop Max Current	24 mA
Current Loop Max V drop	5 V

NB! These characteristics are only applicable to the adapter itself. Voltage and power requirements do not include ROW or level sensor requirements. Refer to corresponding manuals and/or data sheets.

NB! The adapter is intended solely for connecting ROW and a level sensor. Attempting to route the power line to any other equipment through the adapter may damage the device.

Ports

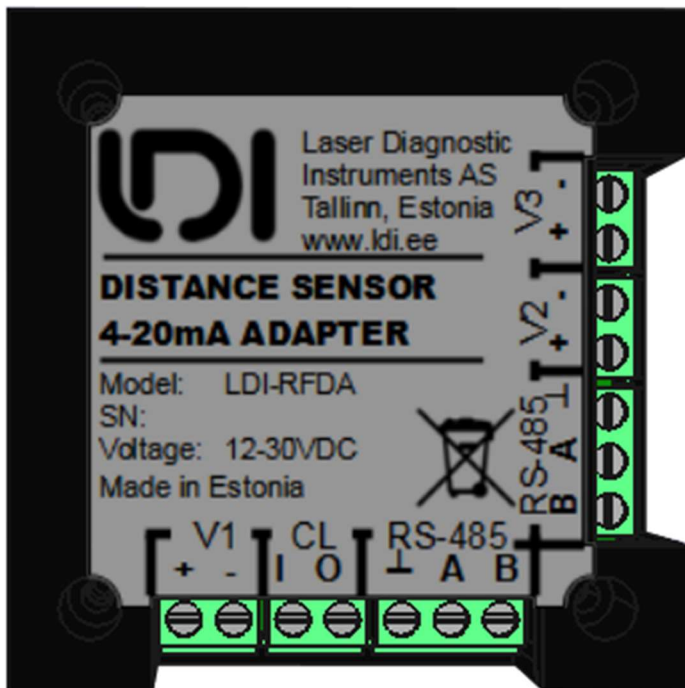

Figure 3. Ports of LDI-RFDA

LDI-RFDA 4-20mA LEVEL SENSOR ADAPTER FOR LDI ROW

- **V1, V2, V3**
 - Power ports. These are used as inputs (from a power source) and outputs (for ROW and level sensor) of power supply.
 - All these ports are internally connected and equivalent.
 - **NB! These ports do not provide any power management for output. Ports will output to ROW and rangefinder the same voltage they are fed from the power source. Make sure both your model of ROW and level sensor support the voltage from your power supply or use a DC-DC converter.**
- **RS-485**
 - These two ports serve to connect ROW and optional monitoring equipment
 - These ports are internally connected, equivalent and are on the same bus
 - “A” is non-inverted signal, “B” is inverted signal, and “⊥” is a ground internally connected with “-” of power ports.
- **CL**
 - Current Loop input port.
 - “O” wire is internally connected to the “-” of power ports.
 - **NB! It is not possible to use other current measuring equipment in series after the LDI-RFDA adapter without a galvanic isolator.**

Connectivity and wiring

There are several different ways to connect the adapter to ROW and the level sensor, depending on the usage scenario and particular model of the equipment used. Most used scenarios are listed below.

Power supply considerations

Power should be supplied to the board by connecting wires from the power source (or the wired power socket) to the V1, V2 or V3 port (V3 by default), observing the correct polarity.

While the board can accept voltages in range of 12 to 30V, power supply voltage should be chosen in regard to the level sensor and ROW voltage requirements.

Different models of rangefinders may have different requirements. While some may work with 12VDC, other require higher voltage. Current loop powered level sensors usually require power supply of 18 V and higher.

Connecting ROW

LDI-RFAD should be connected to ROW using RS-485. RS-485 wires from ROW may be connected directly to one of RS-485 ports of the adapter.

Wire “3” of ROW should be connected to “A” port of the adapter, wire “4” to the “B” port, and wire “7” to the “⊥” port.

LDI-RFDA 4-20mA LEVEL SENSOR ADAPTER FOR LDI ROW

Power wiring depends on the model of ROW and the power supply voltage.

For ROW model O2311 (standard) wires “1” and “2” can be connected directly to the “+” and “-” respectively of either V1, V2 or V3 port of LDI-RFDA (V2 by default).

For ROW model O4500 (Light Fractions), if the power supply exceeds 12V, a DC-DC converter with an output of 12V is required.

NB! Supplying more than 12V to ROW model O4500 directly will damage the unit!

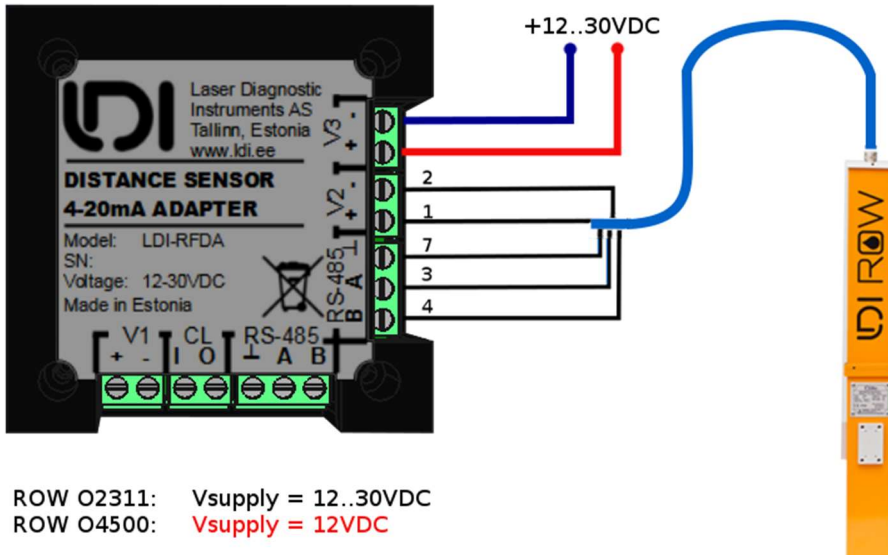

ROW O2311: $V_{supply} = 12..30VDC$
ROW O4500: $V_{supply} = 12VDC$

Figure 4. Wiring ROW O2311 to the adapter

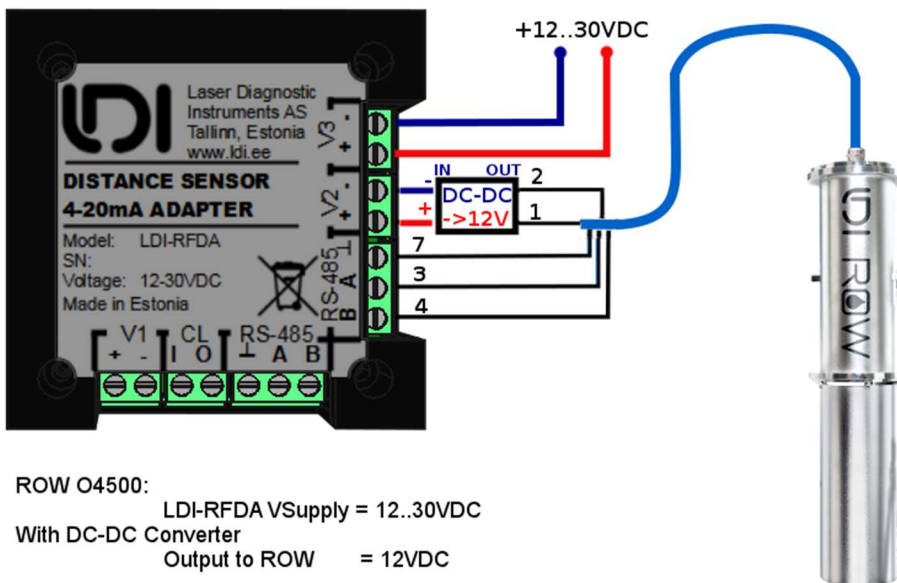

ROW O4500:
LDI-RFDA $V_{Supply} = 12..30VDC$
With DC-DC Converter
Output to ROW = 12VDC

Figure 5. Wiring ROW O4500 to the adapter using a DC-DC converter to supply 12V

LDI-RFDA 4-20mA LEVEL SENSOR ADAPTER FOR LDI ROW

Connecting the level sensor

Wiring of the level sensor will depend on whether the sensor is loop-powered or has an independent power supply.

For loop-powered sensors, the “+” wire of the sensor should go into the “+” of either V1, V2 or V3 (by default V1), while the “-” wire of the sensor should go into the “I” of the CL port.

For sensors with independent power the “+” and “-” wires of the sensor should be connected to a power port of the adapter (by default V1), while the current source wire should be connected into the “I” of the CL port. If the sensor has a current loop common/ground wire, it should be connected to the “O” of the CL port.

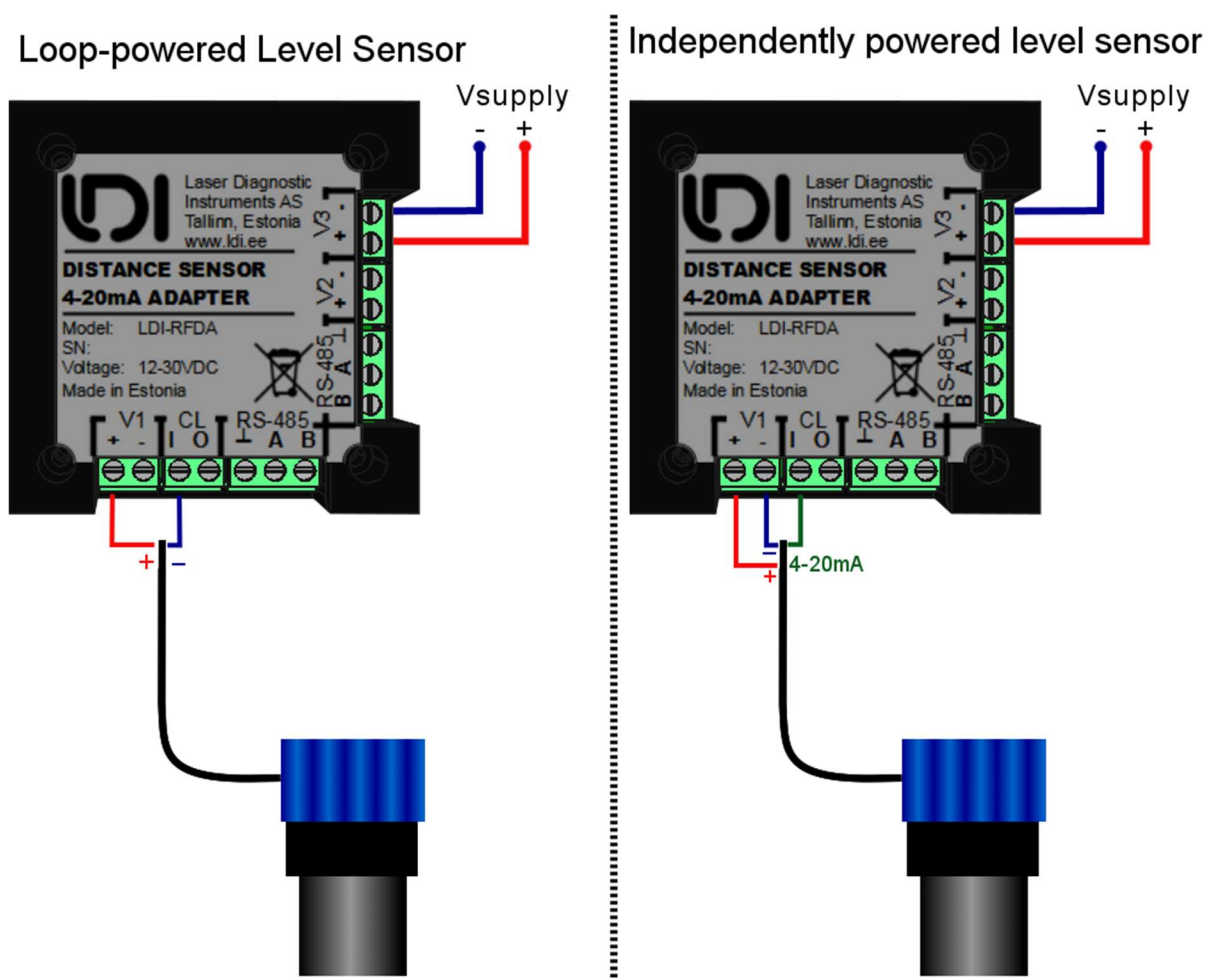

Figure 6. Wiring a level sensor

LDI-RFDA 4-20mA LEVEL SENSOR ADAPTER FOR LDI ROW

RS-485 Monitoring equipment

Other RS-485 equipment, including PLCs to monitor ROW and/or water level, as well as a RS-485 to USB converter to establish connection between ROW and PC, can be connected to the vacant RS-485 port on the adapter.

When connecting the RS-485 equipment, following wiring should be observed:

Terminal	Purpose	DB-9 connector wire
⊥	RS-485 Ground	Grey
A	RS-485 “+” (non-inverted)	Yellow
B	RS-485 “-” (inverted)	Green

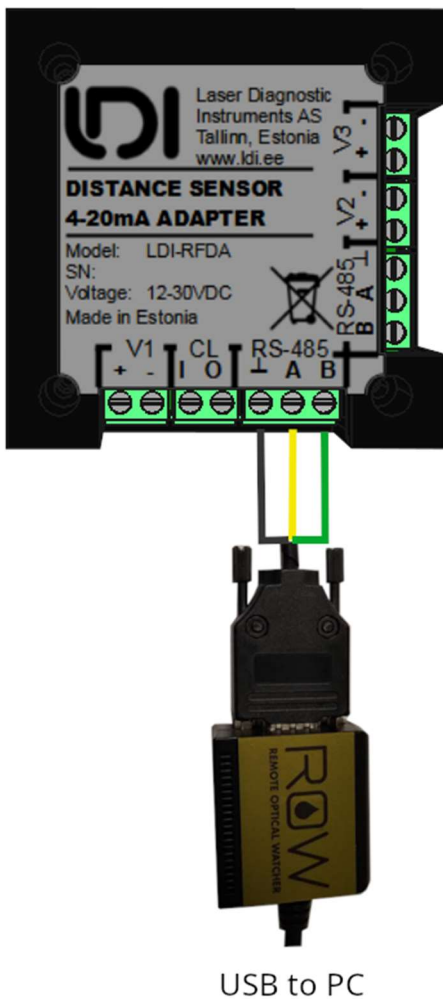

Figure 7. Wiring an optional DB-9 connector

LDI-RFDA 4-20mA LEVEL SENSOR ADAPTER FOR LDI ROW

ATEX considerations

If it is intended to use ROW (Ex version) with an Ex-certified rangefinder in an ATEX environment, it is important to keep a few things in mind:

1. **The LDI-RFDA adapter itself is not ATEX-certified!** Therefore, the adapter should always be located in the safe (non-explosive) zone, or within an ATEX-certified enclosure or junction box.
2. If the level sensor is certified as intrinsically safe (Ex i) without encapsulation/flameproof certification, it will require a galvanic isolator or other form of safety barrier.
3. **Make sure to study the ATEX-related documentation provided in ROW User Manual, as well as the level sensor manufacturer and act in accordance with the requirements stated by corresponding documents.**

An example of using an ATEX (Ex ia) certified ultrasonic level sensor (Dinel ULM-70Xi) is provided. Since the level sensor is certified as intrinsically safe, a galvanic isolator (IRU-420-I) is required for ATEX compliance, as stated in the manufacturer's documentation.

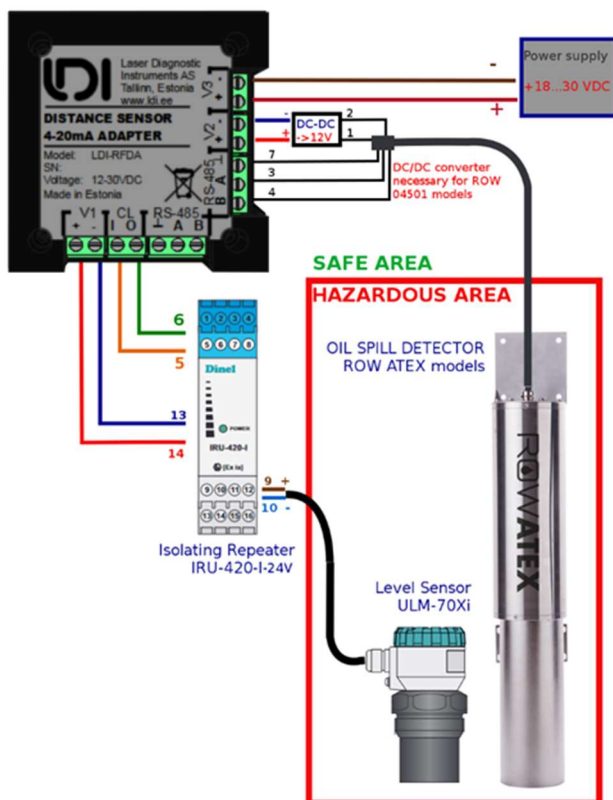

Figure 8. Wiring for an ATEX level sensor Dinel ULM-70Xi

Configuration and setup

Once connected to ROW, level sensor and power supply, LDI-RFDA adapter will function immediately without any further adjustments. However, for correct operation of the adapter, the 4-20mA interface configuration of the level sensor should match that of the adapter.

4-20mA Current Loop Configuration

The 4-20mA current loop transmits data as an analog signal, where the value (in this case, distance to water) is represented as current and mapped to the range of 4 to 20 mA.

Current loop configuration means setting minimum and maximum distance values to correspond to 4 mA and 20 mA respectively. These values should match on the level sensor and the adapter side.

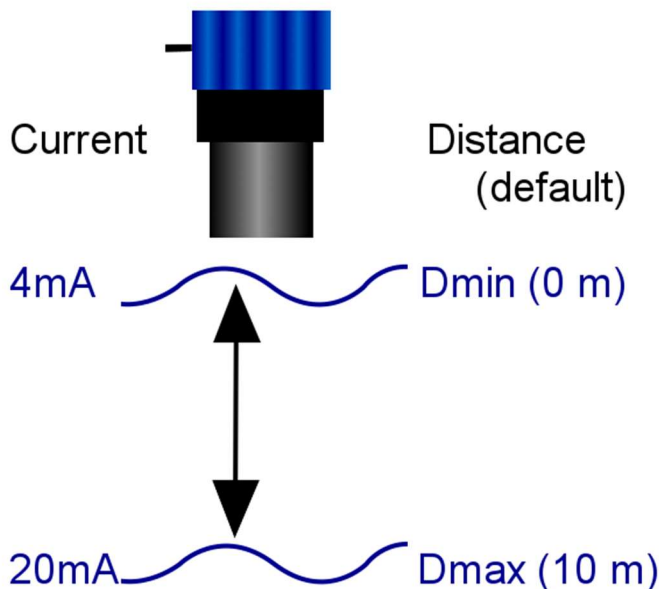

Figure 9. Mapping the distance to current

Default current loop configuration for LDI-RFDA:

- 4 mA -> 0 meters
- 20 mA-> 10 meters

The level sensor should be configured to the same values. If this configuration cannot be set on the level sensor, or if a different range is required, the LDI-RFDA adapter may be reconfigured to the necessary values.

LDI-RFDA 4-20mA LEVEL SENSOR ADAPTER FOR LDI ROW

Some level sensors use “inversed” logic for the 4-20mA interface, where 4 mA corresponds to the highest distance and 20 mA corresponds to the lowest. While it is possible to configure the adapter to support this logic, the results will be much less reliable and more error-prone, especially at shorter distances. Therefore, **it is strongly recommended, when possible, to configure the level sensor so that the minimum current is mapped to minimum distance.**

Serial Port Settings

LDI-RFDA adapter communicates with ROW using Modbus RTU over RS-485. It is also possible to read level information, as well as configure the adapter, by third party applications using the same medium.

To successfully communicate with ROW, LDI-RFDA requires to have the same baudrate as ROW. **By default, both ROW and the adapter have baudrate set to 57600 bps.** If a different baudrate is required, it should be changed on both devices.

ROW Parameters and Polling

ROW unit with the address 1 and the Rangefinder Distance parameter different from 0, ROW Manager (with “Act as range finder commander”), or ROW Configurator software will poll the level sensor for level info.

Any ROW with the Rangefinder Distance parameter different from 0 will receive the response from LDI-RFDA and interpret it to apply distance correction.

Rangefinder Distance defines how far the level sensor is placed from the water (or any other reference plane) at the moment of installation and is used to calculate relative positions between ROW and the rangefinder. During the operations, ROW will recalculate its distance correction using this parameter, as well as its own Distance and the water level from the rangefinder.

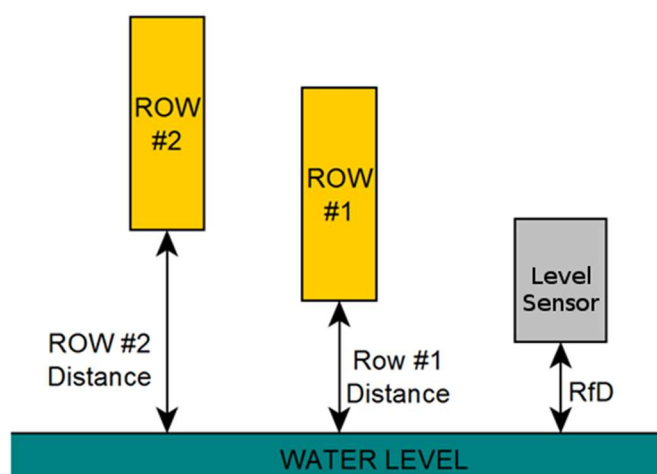

Figure 10. Configuring distances

Advanced functionality

Following functionality is not required for normal day-to-day operations of the adapter.

PLC and Data Logger considerations

In certain applications, ROW will be connected to external monitoring equipment, such as PLCs or Data Loggers, using Modbus. In this context the monitoring equipment will act as a Modbus master (client). LDI-RFDA only acts as a Modbus server, which means it needs to be polled periodically to provide water level. While ROW is capable of polling the adapter itself, it may create collisions on the network due to several devices acting as masters on the single bus.

To avoid these errors, it is recommended to poll the LDI-RFDA adapter from the monitoring equipment. If ROW detects polling on the bus, it will not poll the adapter on its own, but rather read the received packets containing the level information.

To achieve that, the master equipment (data logger or PLC) will have to periodically (recommended interval: 5 seconds) send a certain command on the bus:

0x65 0x03 0x02 0x08 0x00 0x01 0x0C 0x54

LDI-RFDA adapter will respond to this command with a packet containing the level info in a format that ROW will be able to interpret.

Reading the water distance by external devices

If necessary, the level information can be read by external monitoring equipment, such as data loggers or PLCs. The data sent by the adapter can either be in natural format (mm, cm, in), as well as in ROW-readable format.

The level information that is sent as a reply to the periodical polling (command described in the previous section),

Modbus reference and register map

Modbus can be used to change parameters of the LDI-RFDA adapter, as well as to read the water level in a “natural” format.

The Modbus address of LDI-RFDA is hardcoded as 0x65 (decimal 101). Only commands 3 and 16 (decimal) are supported. The register map is provided in the Appendix 1.

Appendix 1. Modbus Register Map

Register (hex)	Register (dec)	Parameter (unit)	Description
Parameter Registers. Supported commands: 0x03 (3), 0x10 (16)			
0x100	256	Service	See (1)
0x101	257	Baud Rate	See (2)
0x102	258	Max Distance (cm)	See 4-20mA Current Loop Configuration
0x103	259	Min Distance (cm)	See 4-20mA Current Loop Configuration
Output Registers. Supported command: 0x03 (3)			
0x200	512	Status	Status register
0x201	513	Reserved	
0x202	514	Current level (uA)	Current Loop in mA * 1000
0x203	515	Distance (cm)	Distance in centimeters
0x204	516	Distance (mm)	Distance in millimeters
0x205	517	Distance (in)	Distance in inches
ROW register (for use with ROW). Supported command. 0x03 (3)			
0x208	519	Distance (ROW)	Distance in ROW-readable format

(1) Service register:

- When read, will output current version
- When written the first bit, will reset the adapter

(2) Baud Rate

- Will accept values from 0 to 6 (default: 1, 57600bps)
 - ◆ 0 -> 115200 bps
 - ◆ 1 -> 57600 bps
 - ◆ 2 -> 38400 bps
 - ◆ 3 -> 28800 bps
 - ◆ 4 -> 19200 bps
 - ◆ 5 -> 9600 bps
 - ◆ 6 -> 4800 bps

(3) Status Register

- 0 indicates no measurement has been performed yet
- 1 indicates successful last measurement
- -1 indicates an error in last measurement (out of range or rangefinder malfunction)